



Tutorial

Primer Design

November 27, 2015

— Sample to Insight —

Primer Design

In this tutorial, you will see how to use the *CLC Main Workbench* to find primers for PCR amplification of a specific region.

We use the pcDNA3-atp8a1 sequence from the 'Primers' folder in the Example data. This sequence is the pcDNA3 vector with the atp8a1 gene inserted. In this tutorial, we wish to design primers that would allow us to generate a PCR product covering the insertion point of the gene. This would let us use PCR to check that the gene is inserted where we think it is.

First, open the sequence in the Primer Designer. You can do this in different ways:

Open the pcDNA3-atp8a1 sequence by double-clicking on the sequence name in the Navigation Area | Shift to the Primer Designer view by clicking on the icon () in the lower left corner of the View Area

or:

Toolbox | Primers and Probes () | Design Primers ()

This will open a wizard. Select the pcDNA3-atp8a1 sequence from the 'Primers' folder in the Example data by double-clicking on the sequence name or by clicking once on the sequence name and then on the arrow in the center of the wizard pointing to the right hand side. Click on the button labeled **OK**.

Now the sequence is opened and we are ready to begin designing primers (see figure 1).

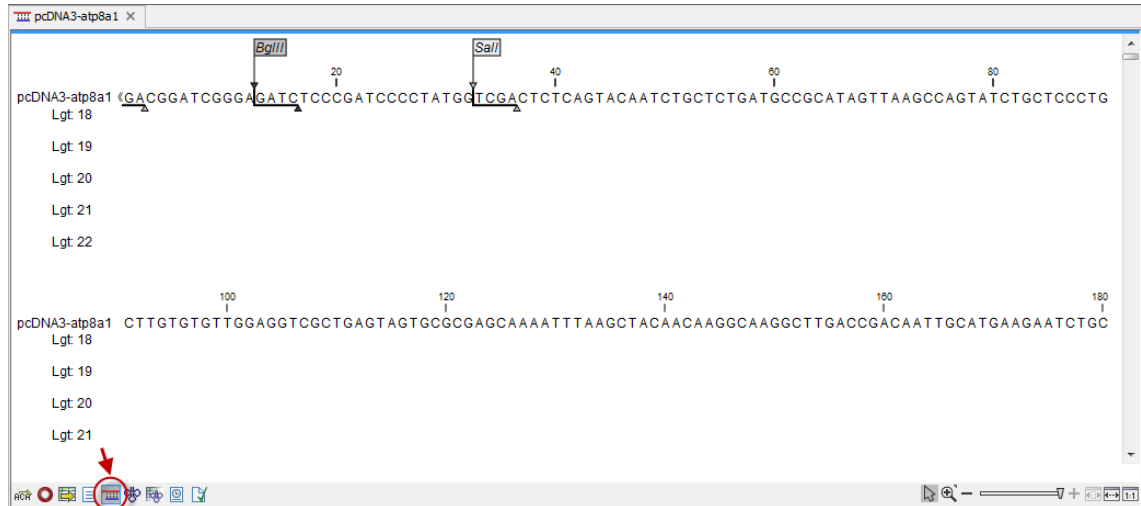



Figure 1: The sequence that you would like to design primers to. The sequence has been opened in the Primer Designer. The red arrow highlights the icon that symbolizes the Primer Designer view.

Specifying a region for the forward primer

When opening the sequence in the Primer Designer view, the sequence is shown at single nucleotide resolution. To get an overview of the sequence, we will zoom out a bit by clicking on the **Fit Width** icon () that are found in the lower right corner of the **View Area**. You can now see the blue gene annotation labeled Atp8a1, and just before that there is the green CMV promoter (see figure 2). This may be hidden behind restriction site annotations. Remember that you can always choose not to Show these by altering the settings in the right hand pane.

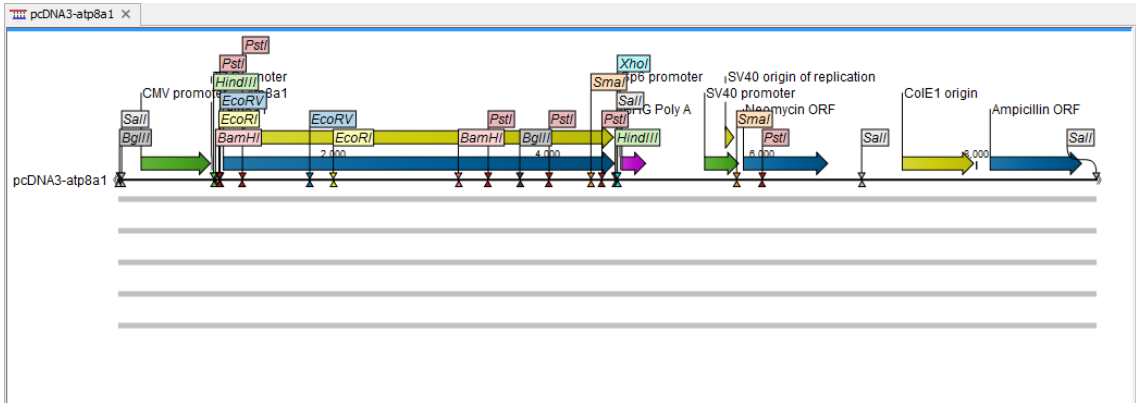

Figure 2: Zoom out to get an overview of the sequence.

In this tutorial, we want the forward primer to be in a region between positions 600 and 900 - just before the gene and we will zoom in (🔍) with the zoom in tool (🔍) found in the lower right corner to make the selection.

Select this region, right-click and choose "Forward primer region here" (⇒) (see figure 3).

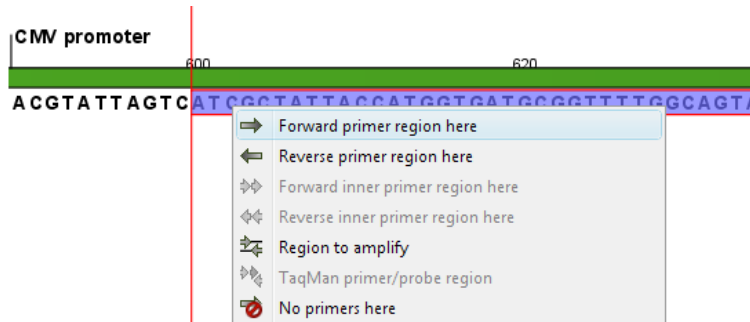

Figure 3: Right-clicking a selection and choosing "Forward primer region here".

This will add an annotation to this region, and five rows of red and green dots are seen below as shown in figure 4:



Figure 4: Five lines of dots representing primer suggestions. There is a line for each primer length - 18bp through to 22 bp.

Examining the primer suggestions

Each line consists of a number of dots, each representing the *starting point* of a possible primer. E.g. the first dot on the first line (primers of length 18) represents a primer starting at the dot's position and with a length of 18 nucleotides (shown as the white area in figure 5):

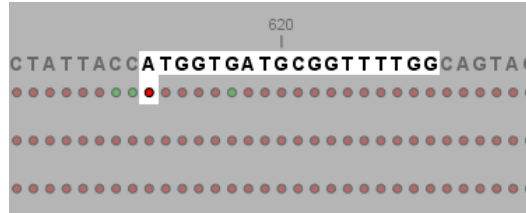

Figure 5: The first dot on line one represents the starting point of a primer that will anneal to the highlighted region.

Position the mouse cursor over a dot. A box will appear, providing data about this primer. Clicking the dot will select the region where that primer would anneal. (See figure 6):

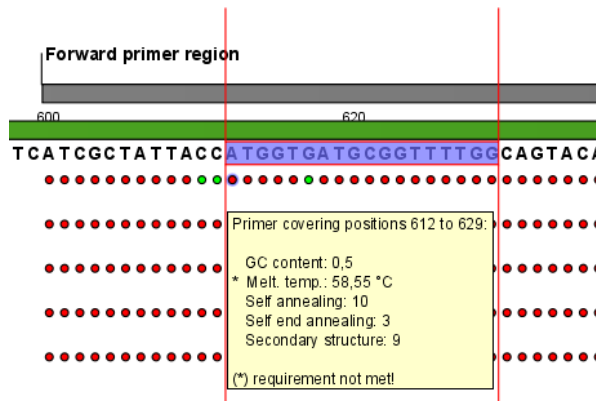

Figure 6: Clicking the dot will select the corresponding primer region. Hovering the cursor over the dot will bring up an information box containing details about that primer.

Note that some of the dots are colored red. This indicates that the primer represented by this dot does not meet the requirements set in the **Primer parameters** (see figure 7):

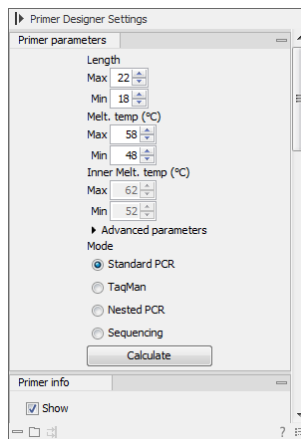

Figure 7: The Primer parameters.

The default maximum melting temperature is 58. This is the reason why the primer in figure 6 with a melting temperature of 58.55 does not meet the requirements and is colored red. If you raise the maximum melting temperature to 59, the primer will meet the requirements and the dot becomes green.

In figure 6 there is an asterisk (*) before the melting temperature. This indicates that this primer does not meet the requirements regarding melting temperature. In this way, you can easily see why a specific primer (represented by a dot) fails to meet the requirements.

By adjusting the **Primer parameters** you can define primers to meet your specific needs. Since the dots are dynamically updated, you can immediately see how a change in the primer parameters affects the number of red and green dots.

Calculating a primer pair

Until now, we have been looking at the forward primer. To mark a region for the reverse primer, make a selection from position 1200 to 1400 and:

Right-click the selection | Reverse primer region here (↔)

The two regions should now be located as shown in figure 8:

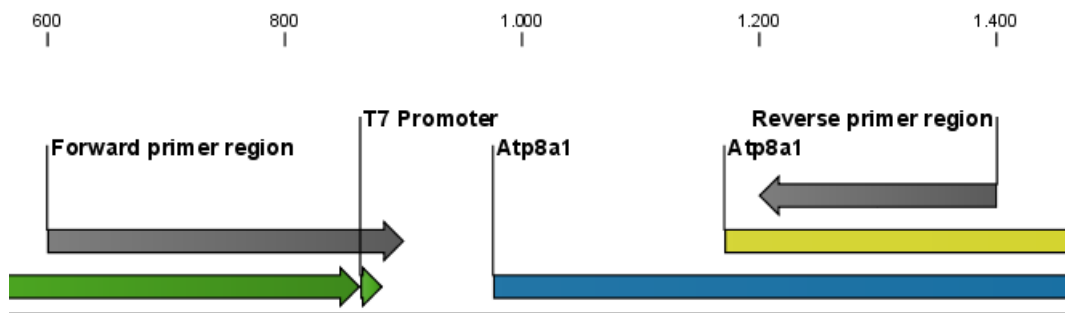

Figure 8: A forward and a reverse primer region.

Now, you can let *CLC Main Workbench* calculate all the possible primer pairs based on the **Primer parameters** that you have defined:

Click the Calculate button (right hand pane) | Modify parameters regarding the combination of the primers (for now, just leave them unchanged) | Calculate

This will open a table showing the possible combinations of primers. To the right, you can specify the information you want to display, e.g. showing **Fragment length** (see figure 9):

Clicking a primer pair in the table will make a corresponding selection on the sequence in the view above. At this point, you can either settle on a specific primer pair or save the table for later. If you want to use e.g. the first primer pair for your experiment, right-click this primer pair in the table and save the primers.

You can also mark the position of the primers on the sequence by selecting **Mark primer annotation on sequence** in the right-click menu (see figure 10):

This tutorial has shown some of the many options of the primer design functionalities of *CLC Main Workbench*. You can read much more using the program's **Help** function (?) or in the *CLC Main Workbench* user manual, linked to on this webpage: <http://www.clcbio.com/download>.

Score	Sequence	Region	GC content	Melt. temp.	Secondary structure score	Secondary structure
42,82	GGGGTCATTAGTCATAG	Fwd (275, 292)	0,44	50,09	9,00	
40,74	TTACGGGTCATTAGTCA	Fwd (271, 289)	0,42	53,65	12,00	
40,74	TACGGGTCATTAGTCA	Fwd (272, 289)	0,44	53,87	12,00	

Figure 9: A list of primers. To the right are the Side Panel showing the available choices of information to display.

The top part of the screenshot shows a sequence map for pcDNA3-atp8a1. It includes a T7 Promoter, a forward primer region, the Atp8a1 gene, and a reverse primer region. The bottom part shows a primer table with a right-click menu open over a row. The menu options are:

- Open Primer(s) Fwd, Rev
- Save Primer(s) Fwd, Rev
- Mark Primer Annotation on Sequence
- Open Fragment
- Save Fragment

The primer table below shows the following data:

Score	Pair annealing align (Fwd,Rev)	Fragment length...	Sequence Fwd	Melt. temp. Fwd	Sequence Rev	Melt. temp. Rev
62,56	GCTGGAGGCTCTATATAA AAGGAGATAAGAGTCAAGG		48,572	GGAAGTGAATAGAGGAA	49,094	
57,873	GCTGGAGGCTCTATATAA AGGAGATAAGAGTCAAGG		48,572	GGAAGTGAATAGAGGA	49,566	

Figure 10: The options available in the right-click menu. Here, "Mark primer annotation on sequence" has been chosen, resulting in two annotations on the sequence above (labeled "Oligo").